

BODYCRAFT

INSTRUCTION MANUAL LEG PRESS OPTION OF GXP GYM

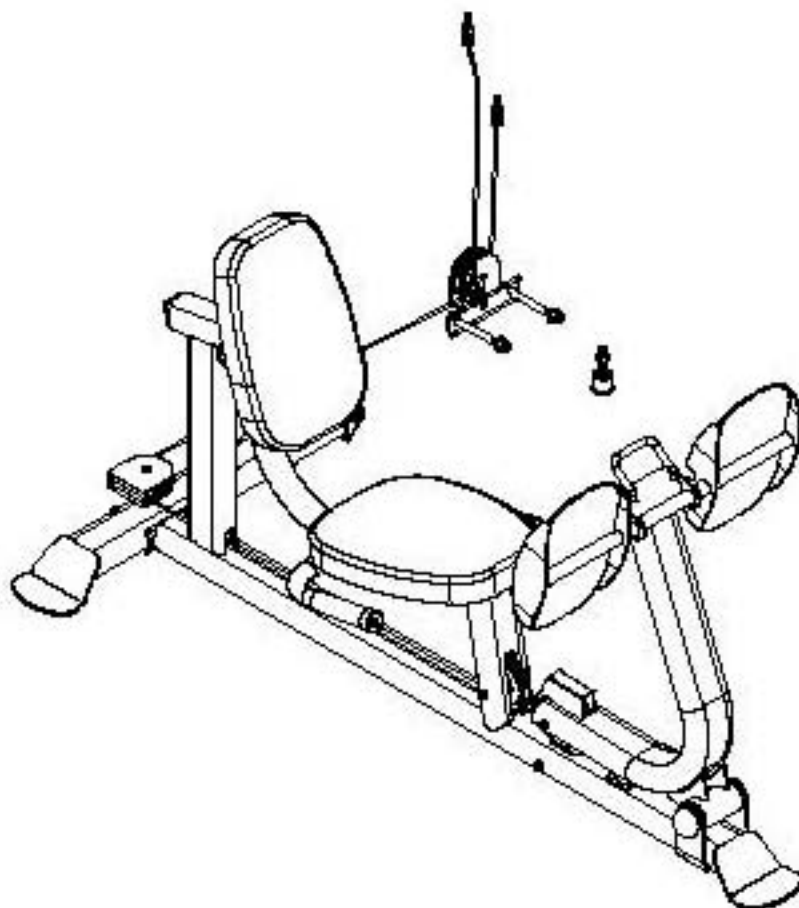

Questions?

As a quality home gym supplier we are committed to your complete satisfaction. If you have questions or find missing or damaged parts, we will guarantee your complete satisfaction through our authorized dealer service centers or our home office customer service department. Please call your local dealer for assistance or BODYCRAFT at 800-990-3536 (9:00 AM - 5:00 PM). Our trained technicians will provide immediate assistance to you, free of charge.

We stand behind our products. Every piece, every part of this BODYCRAFT strength training system is guaranteed for as long as you own it. We will repair or replace anything that goes wrong.

*Bodycraft is a division of Recreation Supply Inc.
P. O. Box 181
Sunbury, OH 43074*

MA709LP

BEFORE YOU BEGIN

Congratulations and thank you for selecting the **Bodycraft GXP Leg Press attachment**. The **Bodycraft GXP Leg Press attachment** offers exercises for strengthening and shaping all leg muscles.

Whether your goal is cardiovascular fitness, a shapely, toned body or dramatic muscle size and strength, the **Bodycraft GXP Leg Press attachment** will help you achieve the specific results you want.

For your safety and benefit, read this manual and the accompanying literature before using the **Bodycraft GXP Leg Press attachment**. Keep this manual for future reference. If you have additional questions, please call your local **Bodycraft** dealer or our customer service department at 800-990-5556 Monday through Friday, 9 a.m. until 5 p.m. Eastern Time.

IMPORTANT SAFETY NOTES

There is a risk assumed by individuals who use this type of equipment. Before beginning this or any other exercise program consult your physician. This is especially important for individuals over the age of 35 or persons with pre-existing health problems. Recreation Supply, Inc. assumes no responsibility for personal injury or property damage sustained by or through use of this product.

1. This product must be assembled on a flat, level surface to assure its proper function.
2. Clean pads and frame on a regular basis. We recommend warm, soapy water. Do not use harsh or abrasive chemicals.
3. Inspect and tighten all parts before every use. Replace any worn parts immediately. Failure to do so may result in serious injury.
4. Keep children away from the **Bodycraft GXP Leg Press attachment** at all times.
5. Keep your hands away from cables and pulleys during operation. Keep your hands away from moving parts other than the designated handles.
6. Make certain all cables are seated within the pulleys before every use.
7. Exercise with care to avoid injury.
8. If unsure about the proper use of the **Bodycraft GXP Leg Press attachment** strength training system call your local **Bodycraft** dealer or our customer service department at 800-990-5556.

EXPLODED

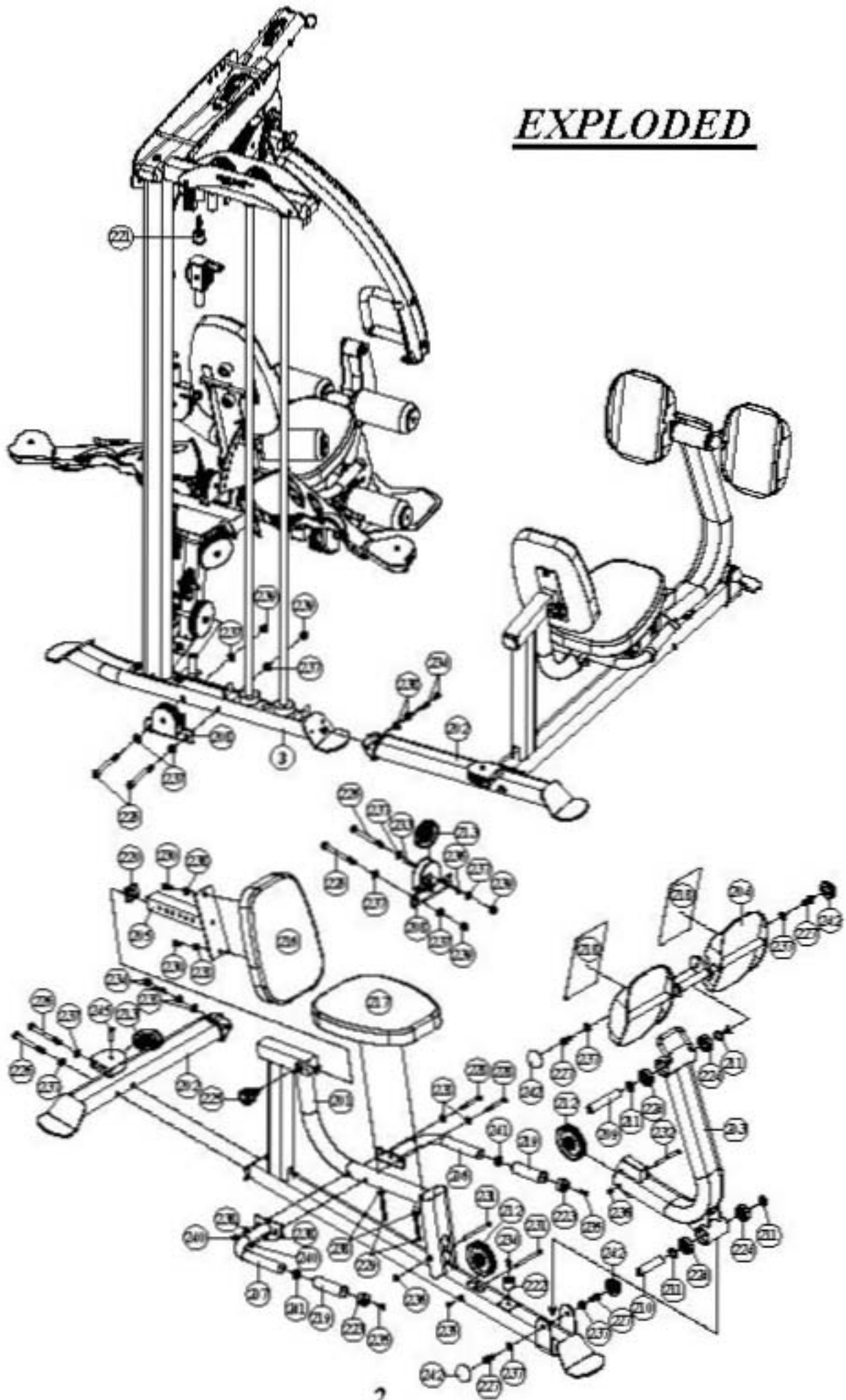

PARTS LIST

NO.	DESCRIPTION	QTY.
201	MAIN FRAME	1
202	CONNECTING REAR STABILIZER	1
203	LEG PRESS SUPPORT	1
204	FOOT PLATE	1
205	BACK PAD ADJUSTER	1
206	LEFT PRESS HANDLE	1
207	RIGHT PRESS HANDLE	1
208	PULLEY BRACKET	1
209	φ25mm AXLE	1
210	φ3/4" AXLE	1
211	COLLAR	4
212	114mm PULLEY	2
213	90mm PULLEY	2
214	CABLE GUIDE CABLE	1
215	LEG PRESS CABLE	1
216	BACK PAD	1
217	SEAT PAD	1
218	NON SLIP	2
219	1-1/4" X 360mm HAND GRIP (pre-assembled)	2
220	45 X 45mm SQ. PLUG	1
221	PLASTIC STOPPER	1
222	LEG PRESS STOPPER	1
223	SEAT PAD SUPPORT STOPPER	2
224	BEARING	4
225	LOCKING SPRING KNOB	1
226	1/2" X 5" HEX BOLT	4
227	1/2" X 1" HEX THREADED BOLT	4
228	3/8" X 3-1/4" HEX BOLT	2
229	3/8" X 2-3/4" HEX THREADED BOLT	2
230	3/8" X 1" HEX THREADED BOLT	2
231	3/8" X 109.5mm FLAT SCREW	2
232	3/8" X 99.5mm FLAT SCREW	1
233	3/8" X 30.5mm FLAT SCREW	1
234	3/8" X 3/4" ROUND HEAD SCREW	3
235	5/16" X 1-1/4" MALE SET SCREW	2
236	M6 X 12L MALE SET SCREW	4
237	1/2" WASHER	10
238	3/8" WASHER	10
239	1/2" NYLON NUT	2
240	3/8" NYLON NUT	2
241	5/16" NUT (pre-assembled)	2
242	CAP FOR NUT	4
243	4mm HEX WRENCH	1
244	5mm HEX WRENCH	1
245	3/8" X 1-1/2" FLAT SCREW	1

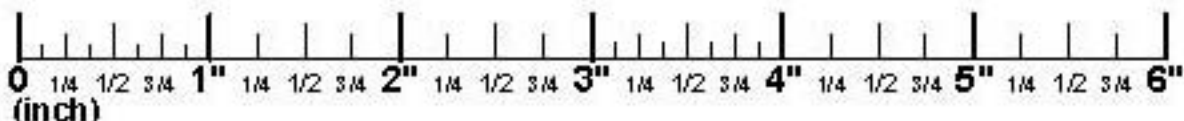
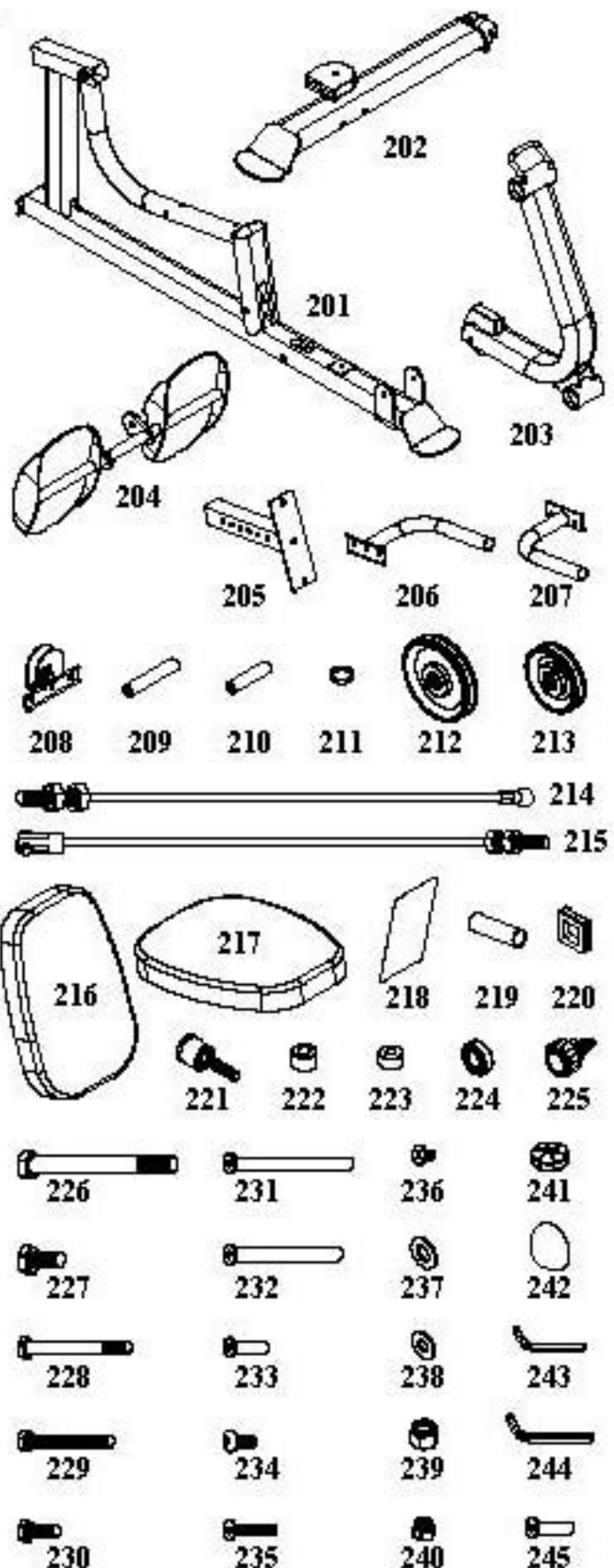

STEP 1 ASSEMBLE MAIN FRAME

To ease assembly , Do Not tighten any bolts until instructed.

1. Attach the Connecting Rear Stabilizer (202) to the GXP Base Frame (1), using two 3/8" X 3/4" Hex Bolts (234), two 3/8" Washers (238).
2. Attach Pulley Bracket (208) to the GXP Rear Stabilizer (3), using two 1/2" X 5" Hex Bolts (226), four 1/2" Washers (237) and two 1/2" Nylon Nuts (239).

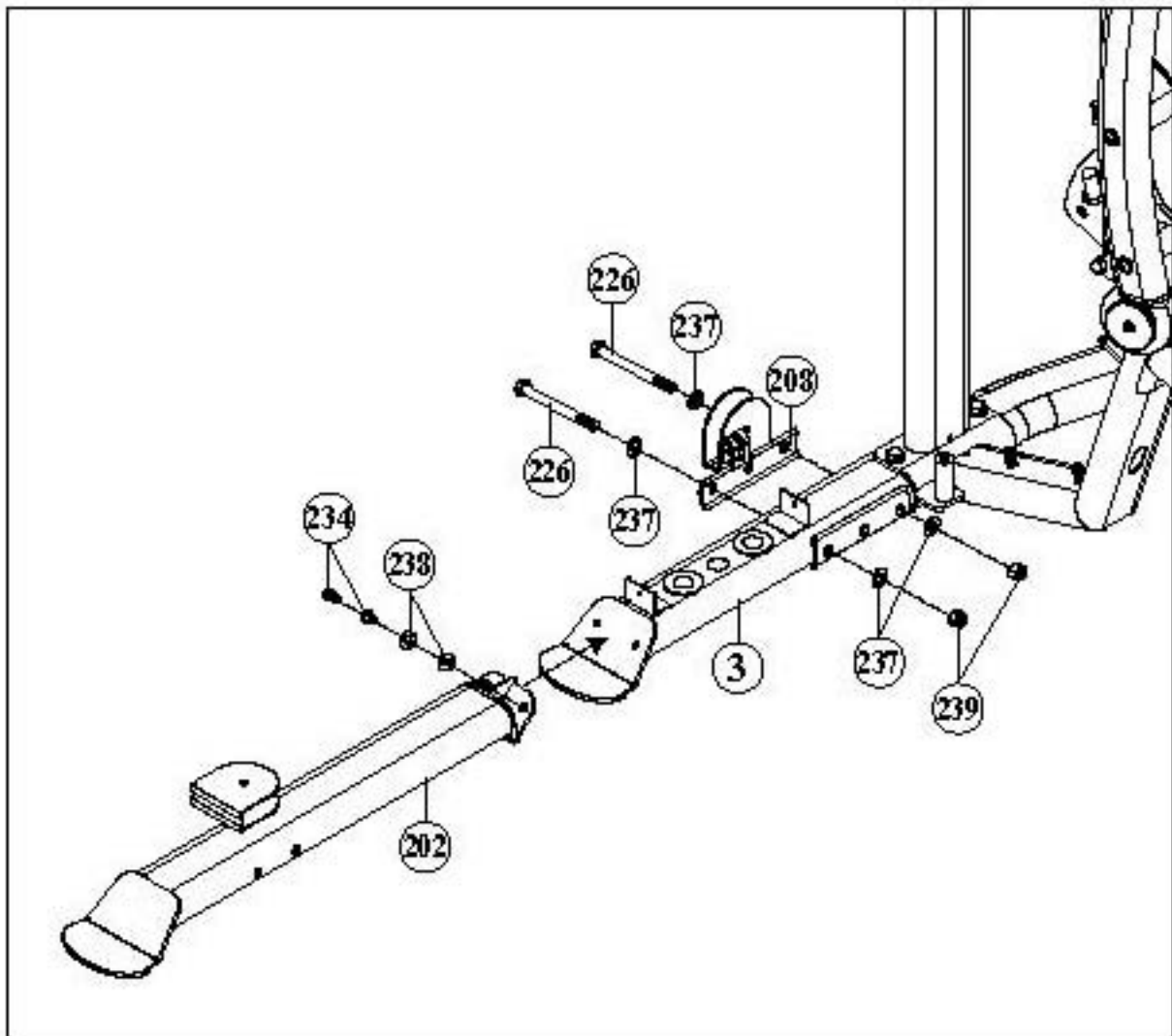

STEP 2 ASSEMBLE MAIN FRAME

1. Attach the Main Frame (201) to the Connecting Rear Stabilizer (202), using two 1/2" X 5" Hex Bolts (226), four 1/2" Washers (237).
2. Insert the 25mm Axle (209) into the Leg Press Support (203), then attach to the Main Frame (201) using two Collars (211) (inside bracket of Leg Support (203)), two 1/2" X 1" threaded Bolts (227) and 1/2" Washers (237). Tighten the bolts and cap with two End Caps (242).
3. Insert the 3/4" Axle (210) and two Collars (211) into the top hole in the Leg Press Support (203), then attach to the Foot Plate (204), using two 1/2" X 1" Hex Threaded Bolts (227) and two 1/2" Washers (237). Tighten the bolts and then cap with two End Caps (242).
4. Attach Right and Left Seat Handle (206, 207) to the Main Frame (201), using two 3/8" X 2-3/4" Hex Bolts (228), four 3/8" Washers (238), and two 3/8" Nuts (240). Tighten these bolts.
5. Attach Seat Pad (217) to the Main Frame (201), using two 3/8" X 2-3/4" Hex Threaded Bolts (229) and two 3/8" Washers (238).
6. Attach Back Pad (216) into the Back Pad Adjuster (205), using two 3/8" X 1" Hex Threaded Bolts (230) and two 3/8" Washers (238). Then slide the Back Pad Adjuster (205) to the Main Frame (201) and lock at your desired position using the Spring Knob (225).

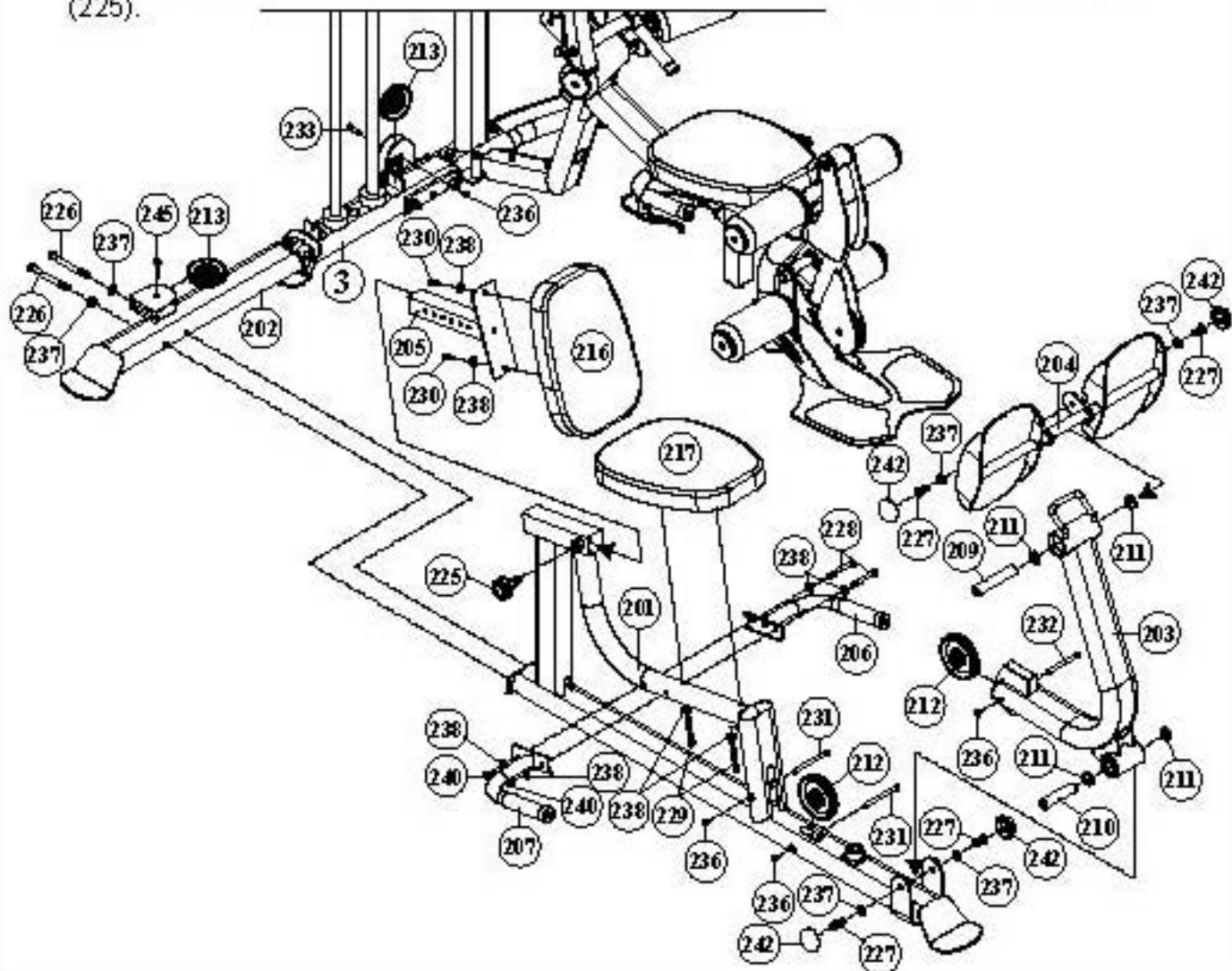

STEP 3 ASSEMBLE PRESS CABLE

Assemble cables and pulleys simultaneously.

1. Locate the Single Pulley Block (24) assembled to the base unit of GXP. Unscrew The Single Pulley Block (24). Screw the Plastic Stopper (221) into the Top Frame (2) in the place of the Single Pulley Block (24). Flip the Single Pulley Block (24) over (You will need to remove the pulley when doing this) so that the flat end of the Single Pulley Block (24) is resting against the Plastic Stopper (221) as shown in Fig. L1.
2. Screw the threaded end of Leg Press Cable (215) about half way into the threaded receptacle in the Single Pulley Block (24). This is an adjustment area where the cable can be tighten or loosened. Be certain to always have at least one third of the threaded end of the cable screwed into the Single Pulley Block (24). Also be certain to tightened the locking nut securely to prevent the cable from unscrewing.
3. Route the flat end of the cable down and under the vertical pulley, mounted in the Pulley Bracket (208), using one 3/8" X 1-1/4" Flat Screw (233) and one M6 X 12L Male Set Screw (236) as shown in Fig. L2.
4. Continue routing cable over to the horizontal pulley mounted to the Connecting Rear Stabilizer (202), using one 3/8" X 1-1/2" Flat Screw (245) as shown in Fig. L3
5. Route the cable under a pulley mounted under the Seat, using one 3/8" X 4-3/8" Flat Screw (231) and one M6 X 12L Male Set Screw (236) as shown in Fig. L4.
6. Continue routing over top of a pulley mounted in the end of the Leg Press Support (203) using one 3/8" X 4-3/8" Flat Screw (231) and one M6 X 12L Male Set Screw (236) as shown in Fig. L5.
7. Attach the flat end of the cable to the base of the Leg Press Support (203), using one 3/8" X 4-3/8" Flat Screw (231) and one M6 X 12L Male Set Screw (236) as shown in Fig. L6.
8. Clip the steel ball end of the Cable Guide Cable (214) into the bracket welded on the base of the Connecting Rear Stabilizer (202), then route the cable up through the steel loop on the Single Pulley Block (24) and screw the threaded end into the receptor welded to the Top Frame (2), as shown in Figs. B1 and B2. Tighten this cable. This cable is a guide that helps eliminate twisting of the Leg Press Cable.

Tighten all bolts, starting from base and working your way up.

STEP 3 ASSEMBLE PRESS CABLE

CABLE GUIDE CABLE (214)

LEG PRESS CABLE (215)

Threaded End Bolt End

Flat End Threaded End

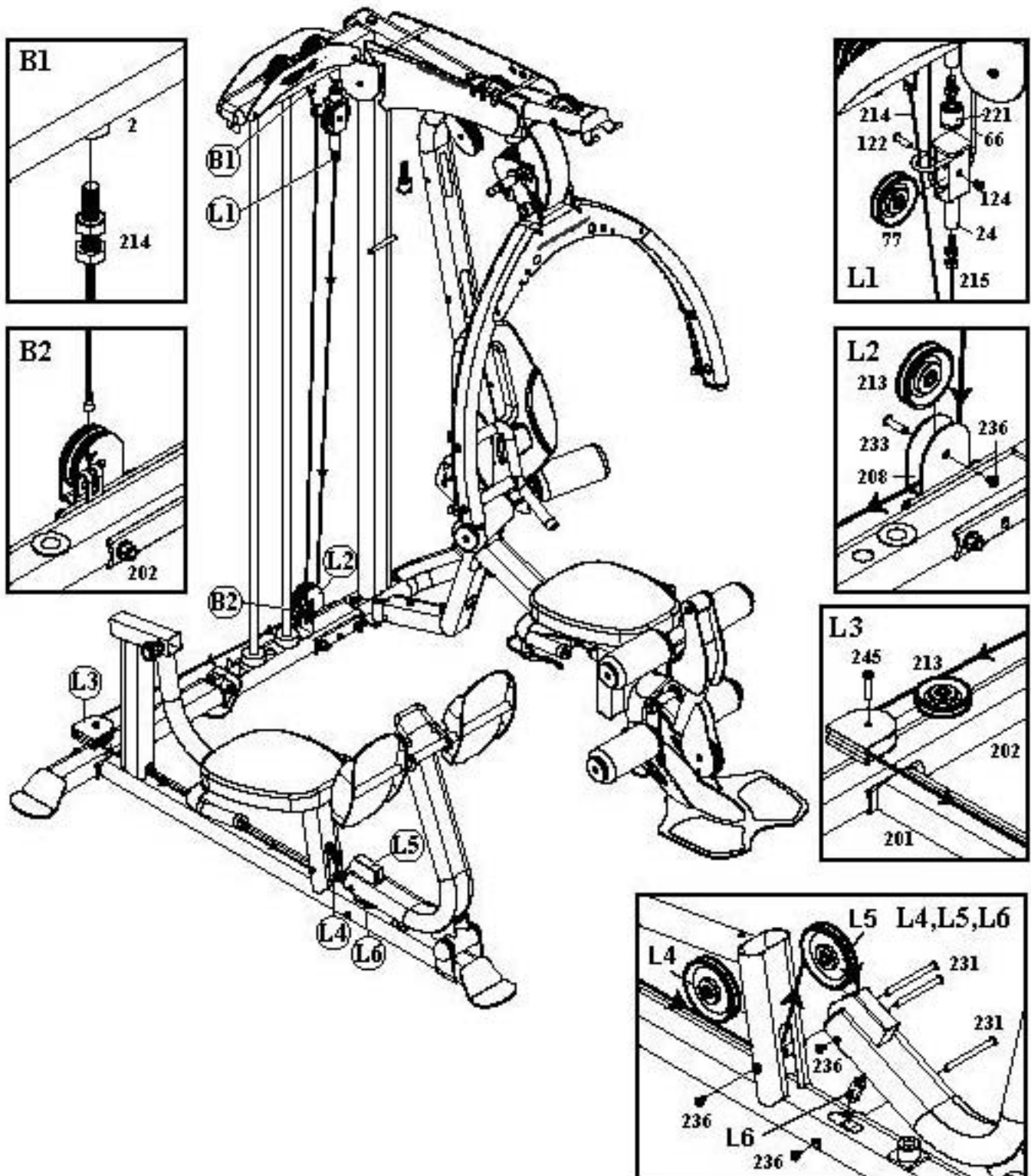

Assembly is complete! Please take the following steps before using the gym:

1. Make certain all bolts are tightened securely.
2. Make certain all cables are seated into all pulley grooves. A cable rubbing-against steel will peel the nylon coating, voiding warranty and resulting in a need for replacement.
3. Pre-stretch the cables. Pull on the cables with great force, helping remove any links and providing any initial cable stretch.
4. Be aware the cables can loosen and slightly stretch upon initial use.
5. For better performance, apply a household lubricant (such as silicone) to any adjustable areas.
6. Enjoy many years of a Fit Lifestyle.

**Thank you for purchasing the Bodycraft GXP Leg Press attachment.
If You have any questions, please call your local BodyCraft dealer
or call our customer service department at 800-990-5556**